

THIS DRAWING IS UNPUBLISHED. RELEASED FOR PUBLICATION
 © COPYRIGHT - By - ALL RIGHTS RESERVED.

LOC		DIST		REVISIONS			
P	LTR	DESCRIPTION		DATE	DWN	APVD	
CM	00	F2	REVISED PER ECO-11-005027		11MAR11	RK	HMR

- 1 WIRE RANGE: 0.13–0.32mm² (26–22 AWG).
- 2 INSULATION RANGE: 1.20–1.75 DIA.
- 3 FINISH: 0.76µm MINIMUM GOLD IN LOCALIZED GOLD PLATE AREA OVER 1.27µm MINIMUM NICKEL
- 4 FINISH: 2.54µm MINIMUM PRE-TIN IN LOCALIZED TIN PLATE AREA.
- 5 FINISH: 2.54µm MINIMUM PRE-TIN ALL OVER.

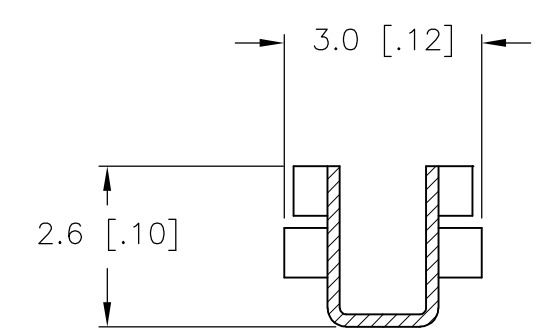
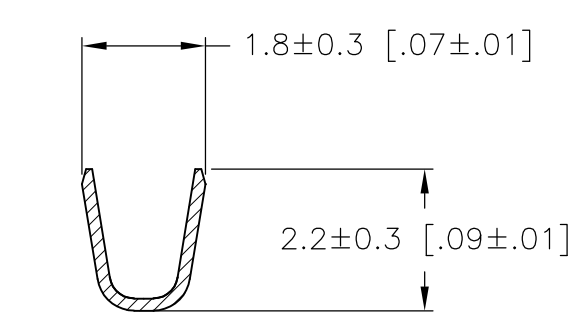
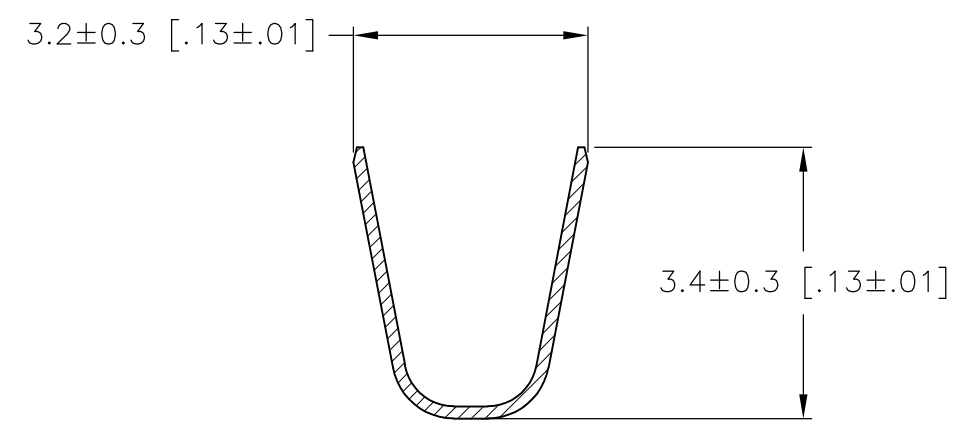
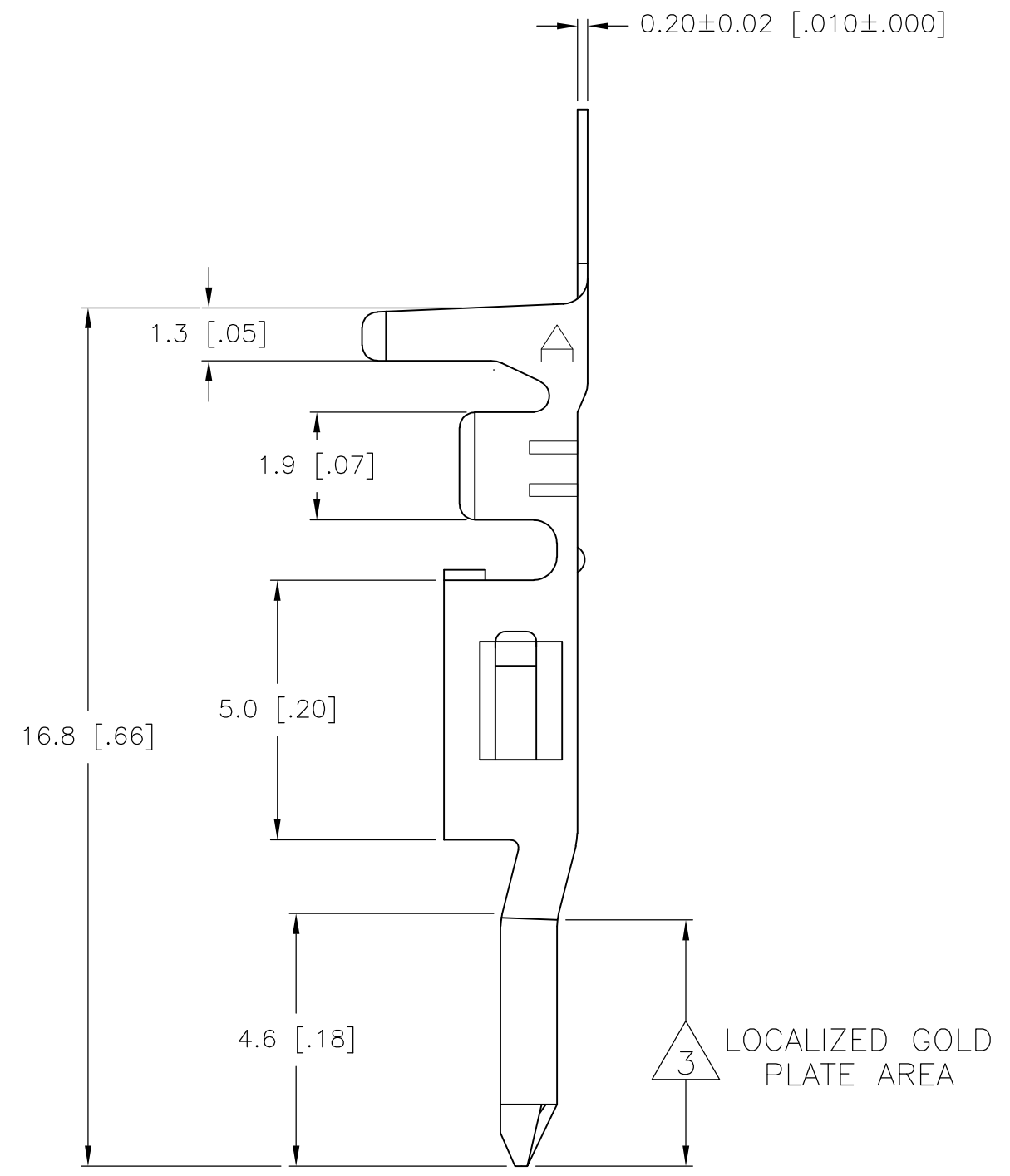
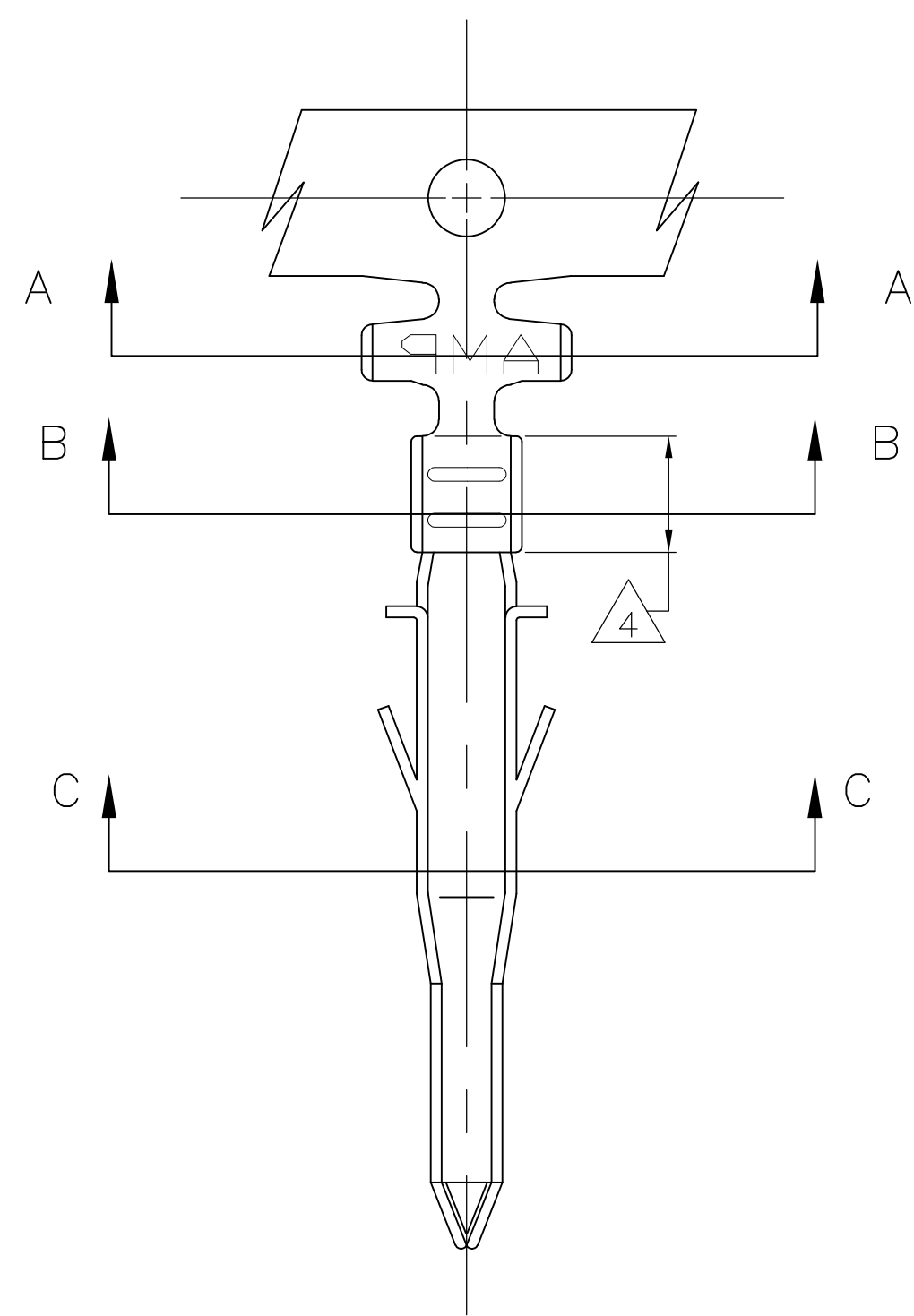

SECTION A-A

SECTION B-B

SECTION C-C

METRIC

GOLD	3 4	PHOS. BRZ.	794957-4
PRE-TIN	5	PHOS. BRZ.	794957-3
GOLD	3 4	BRASS	794957-2
PRE-TIN	5	BRASS	794957-1
FINISH:		MATERIAL:	PART NO.

THIS DRAWING IS A CONTROLLED DOCUMENT.		DWN	S. HAMM	06-SEP-2001	 TE Connectivity								
DIMENSIONS: mm [INCHES]		CHK	D. COLEY	07-SEP-2001									
TOLERANCES UNLESS OTHERWISE SPECIFIED:		APVD	D. COLEY	07-SEP-2001									
0 PLC ± 1 PLC ± 2 PLC ± 0.25 [010] 3 PLC ± 0.15 [.006] 4 PLC ± 0.050 [.0020] ANGLES ±		PRODUCT SPEC	NAME										
MATERIAL	FINISH	APPLICATION SPEC	TERMINAL PIN VAL-U-LOK(TM)		RESTRICTED TO								
CUSTOMER DRAWING		WEIGHT	SIZE	A2	CAGE CODE	00779	DRAWING NO	C=794957	SHEET	1 OF 1	REV	F2	
SCALE		10:1		SCALE		10:1		SHEET		1 OF 1		REV	F2